

THIS DRAWING IS UNPUBLISHED. RELEASED FOR PUBLICATION
 © COPYRIGHT BY TYCO ELECTRONICS CORPORATION. ALL RIGHTS RESERVED.

LOC		DIST		REVISIONS			
P	LTR	DESCRIPTION	DATE	DWN	APVD		
	0	RELEASED.	20JUN2005	JGH	JGH		

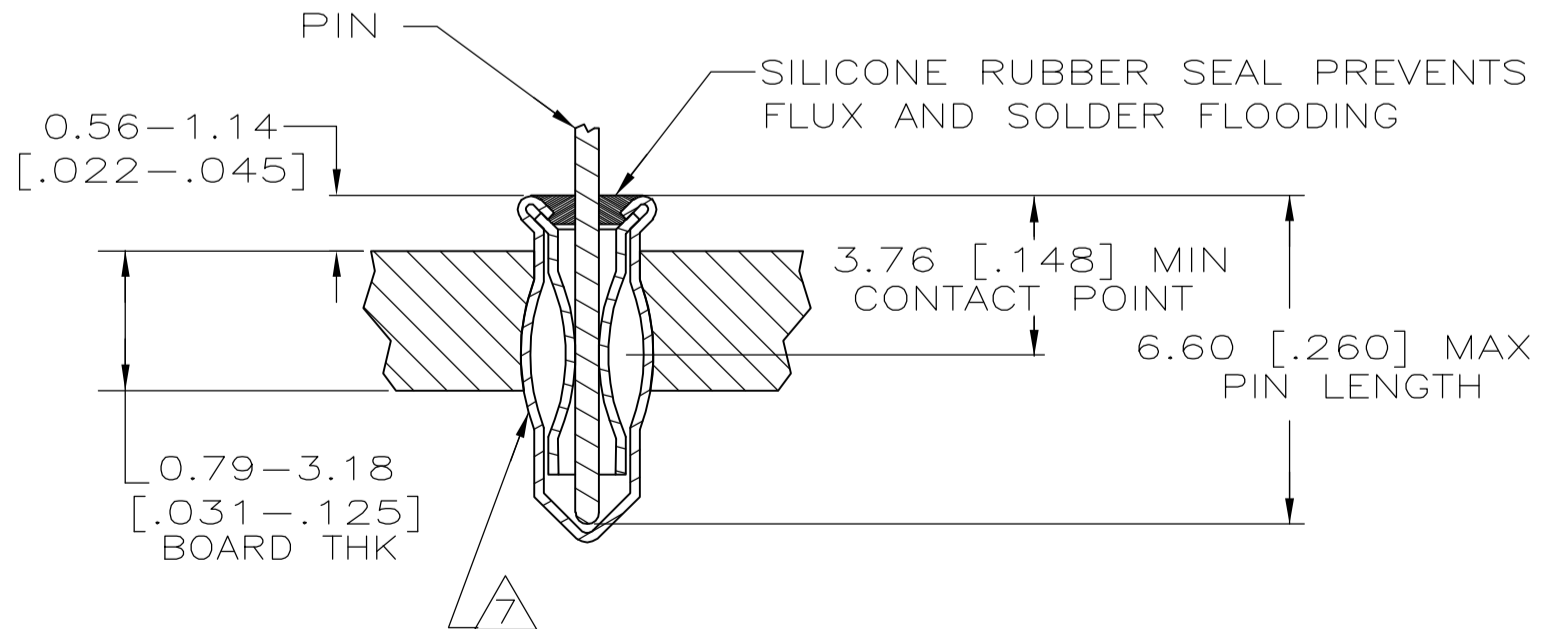
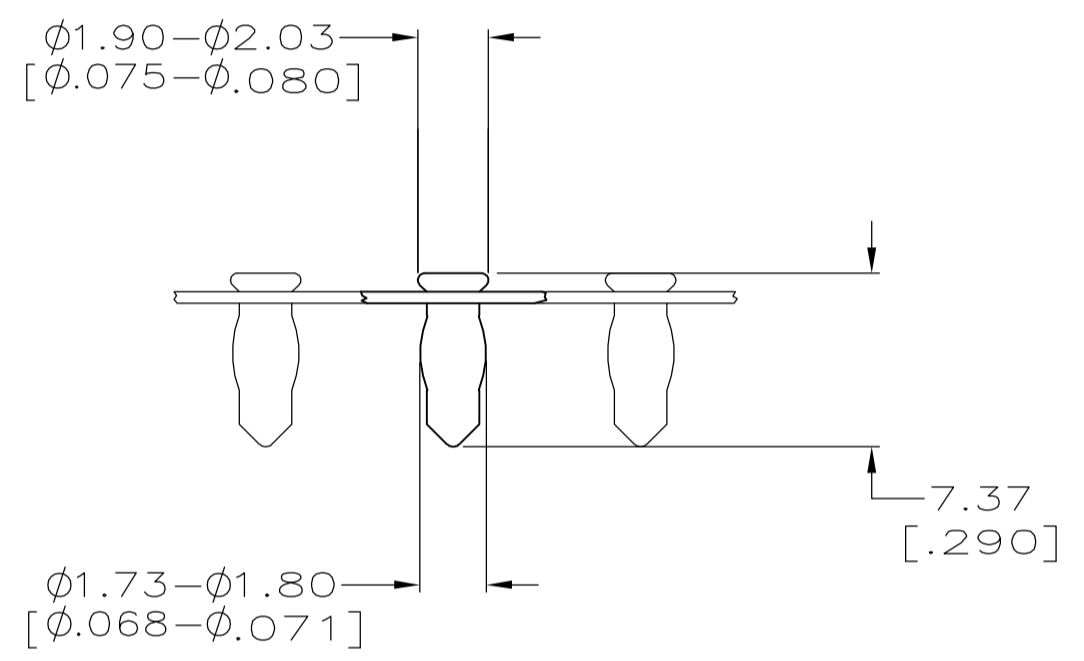
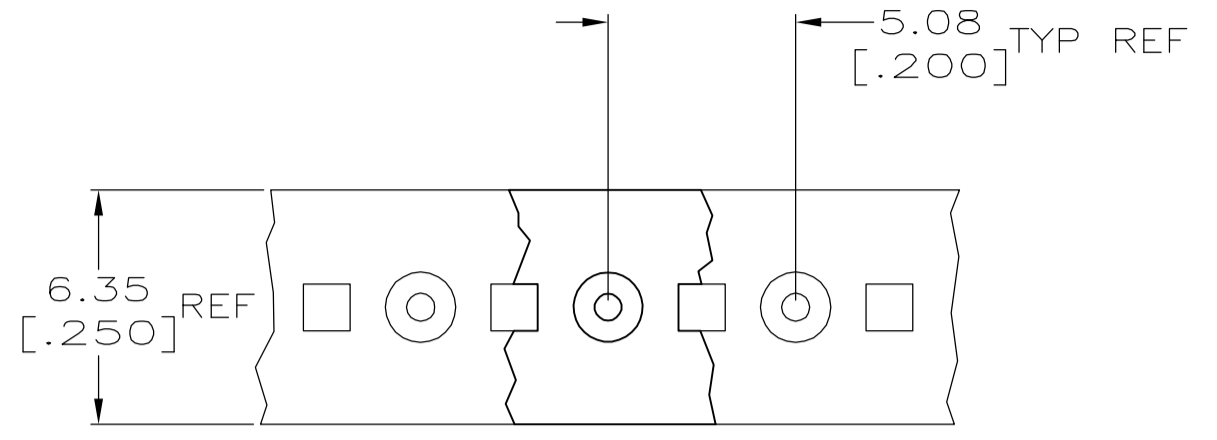

- 1 MATERIAL:
EYELET - COPPER PER ASTM B 152
SPRING - BERYLLIUM COPPER PER ASTM B 194
SEALANT - SILICONE RUBBER
- 2 TIN PLATE PER ASTM B 545 0.00381 [.000150] MIN THK.
- 3 TIN PLATE PER ASTM B 545 0.00254 [.000100] MIN THK.
- 4 GOLD PLATE PER ASTM B 488 0.00076 [.000030] MIN THK ON CONTACT AREA.
- 5 PACKAGED 50,000 PER REEL
- 6 TO INSURE 1/2 OZ MIN RETENTION DO NOT EXCEED 0.10 [.004] DIFFERENCE IN PIN DIA WHEN CHANGING TO A SMALLER DIA PIN
- 7 PRODUCT IS OVALIZED FOR RETENTION IN THE P.C. BOARD. THE RECOMMENDED HOLE DIAMETER IS phi 1.57 [phi 0.062] MINIMUM, +0.08 [.003] MAX. PRIOR TO SOLDERING.
- 8 PACKAGED 10,000 PER REEL

3.76-6.60 [.148-.260]	phi 0.71-phi 0.84 [phi 0.028-phi 0.033]	GOLD 4	TIN 2	8 1-5645986-2
3.76-6.60 [.148-.260]	phi 0.71-phi 0.84 [phi 0.028-phi 0.033]	TIN 3	TIN 2	8 1-5645986-1
3.76-6.60 [.148-.260]	phi 0.71-phi 0.84 [phi 0.028-phi 0.033]	GOLD 4	TIN 2	5 5645986-2
LENGTH	DIA 6	SPRING	EYELET	PART NO.
PIN		FINISH		

THIS DRAWING IS A CONTROLLED DOCUMENT.		DWN J. HAVENER 20JUN2005	tyco Tyco Electronics Corporation Harrisburg, Pa 17105-3608	
DIMENSIONS: mm [INCHES]		CHK J. HAVENER 20JUN2005	APVD J. HAVENER 20JUN2005	
TOLERANCES UNLESS OTHERWISE SPECIFIED: 0 PLC ± - 1 PLC ± - 2 PLC ± - 3 PLC ± 0.20[.008] 4 PLC ± -		NAME MINIATURE SPRING SOCKET ASSY SERIES 3 WITH SEALANT		
MATERIAL 1		FINISH SEE TABLE		SIZE CAGE CODE DRAWING NO RESTRICTED TO A2 00779 C-5645986
CUSTOMER DRAWING		SCALE 10:1 SHEET 1 OF 1 REV 0		

CUSTOMER DRAWING